

**I E T F**

**20 Years of  
People, Places ...**

**... and  
Many Fine Lunches and Dinners**

**IETF 1 San Diego**

**January 1986**

**21 Attendees**

**Host: Linkabit Corporation**



# IETF 8 Boulder, November 1987





**IETF 9 San Diego,  
March 1988**

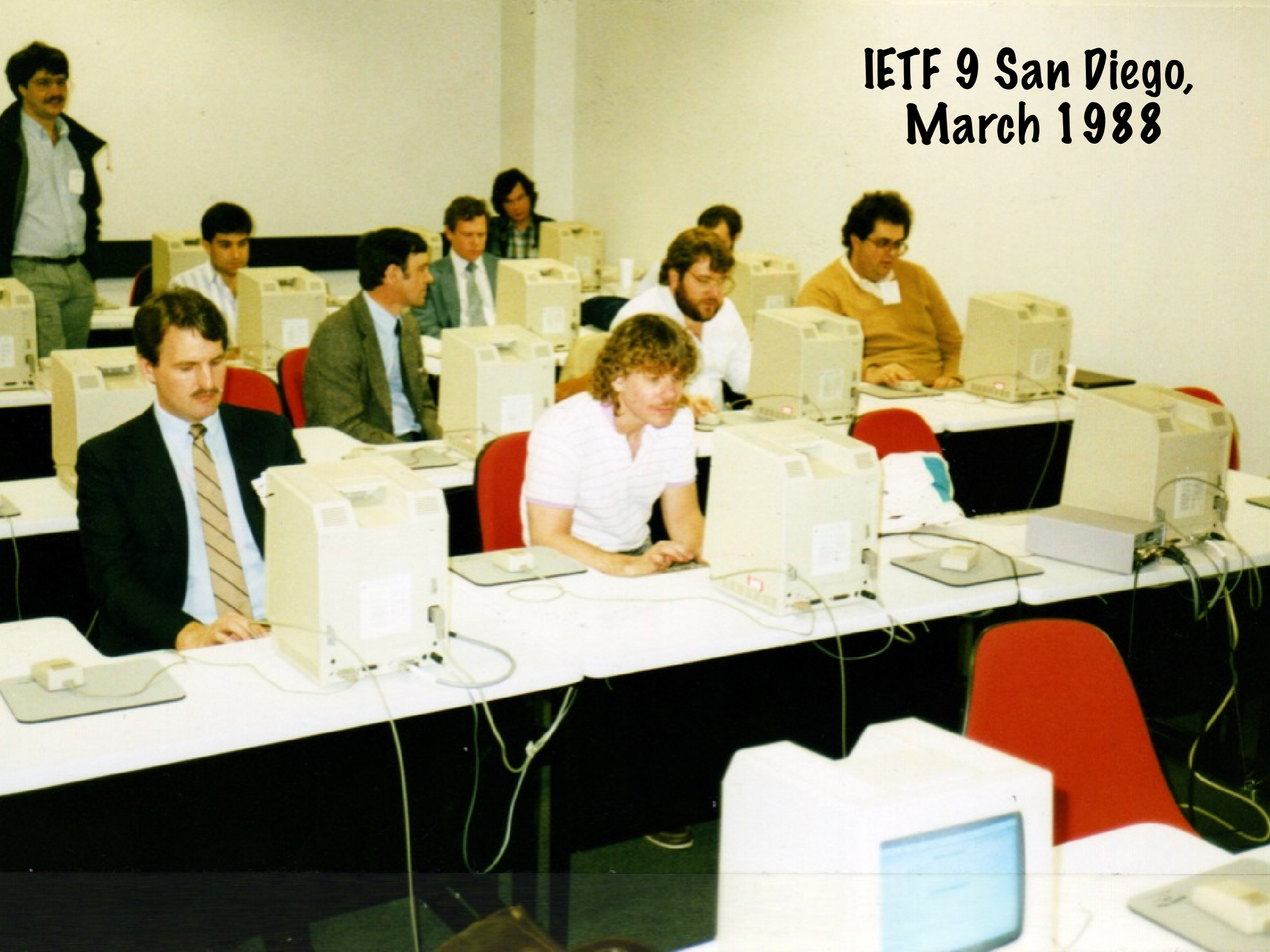



**IETF Chair Phil Gross,  
ca. 1988**

**Remember  
the gong?**

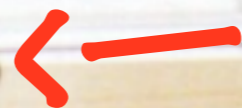



# IETF 10 Annapolis, June 1988

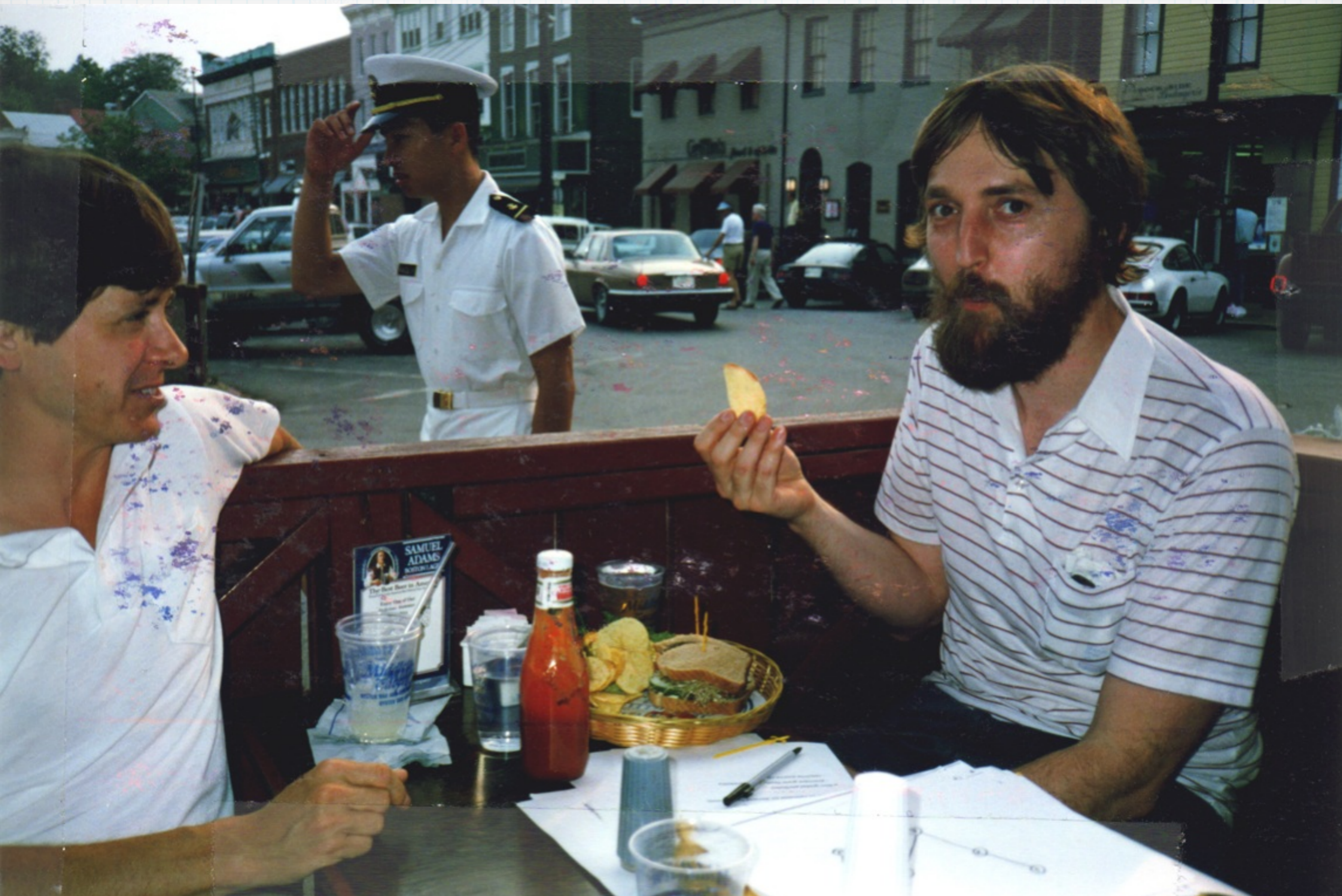



# IETF 10 Annapolis, June 1988

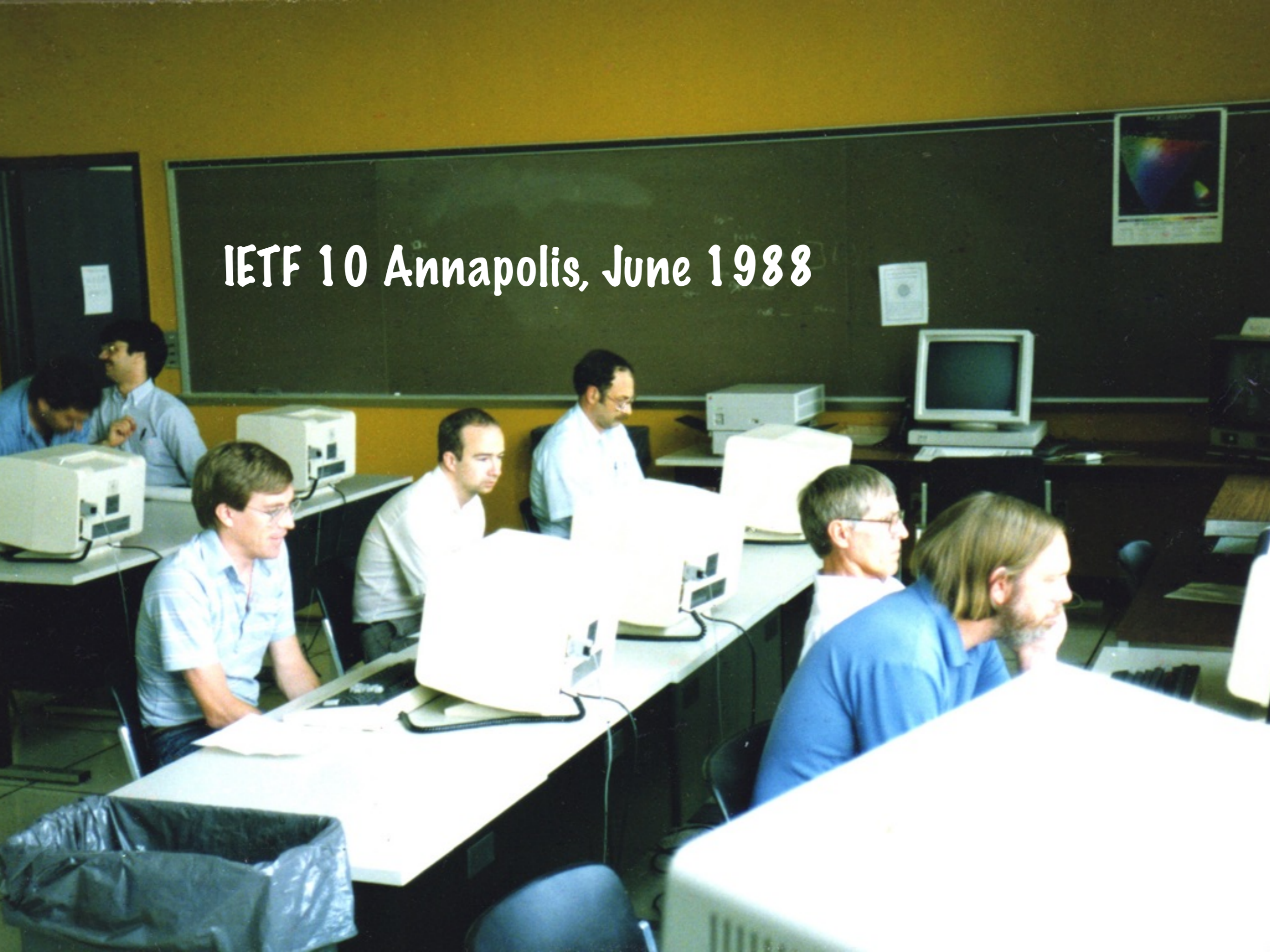



IETF 11 Ann Arbor, October 1988



← NUCLEAR WAR !!!



# ISO Job Ad, 1989:

The International Organization for Standardisation (ISO) is seeking, for its new project based on OSI LAN with distributed environment including servers and VM and VMS hosts (PC or PS/2 user terminals), an experienced

## NETWORK SYSTEMS SPECIALIST

familiar with the hardware/software aspects of LAN, network management and operating systems, terminal emulation and host coupling, OSI protocols including TCP/IP, X.400 and X.25, to be responsible for overall implementation of the network system. Please apply with cv to: ISO Personnel Services, Case postale 56, CH-1211 Geneva 20, Switzerland.

... That made us feel great!





IETF 13 Cocoa Beach,  
April 1989



# IETF 15 Honolulu, October–November 1989



**“Nerds in Paradise”**



IETF 15 Honolulu,  
October–November 1989





# VISITOR

736992

NAVAL BASE PEARL HARBOR

29 OCT 1989

## EXPIRES:

I understand that by acceptance of this pass I agree to submit to search of this vehicle and any packages therein at any time this vehicle is within the Naval Reservation.

Naval Base speed limit—25 MPH unless otherwise posted.  
Naval Base Police Department Phone Number—474-1237

rev 3-77)

**IETF 15 Honolulu,  
October–November 1989**





**IETF 16 Tallahassee,  
February 1990**

← **The IETF Secretariat**



IETF 18 Vancouver,  
July 1990







# IETF 27 Amsterdam, July 1993

153269B |  / NV Nederlandse Spoorwegen

Geldig op 12.07.1993 Uiterste gebruiksdatum 12 JULI 1993 Klasse B

**IETF AMSTERDAM**

SOCIAL EVENT TICKET AND RECEIPT  
"TRAINING THROUGH THE NETHERLANDS"  
VALID ONLY FOR SPECIAL TRAIN

SPONSORED BY:  
**DIGITAL RARE SURFNET BV**

Afgiftepunt 149.061 Atrekeningsnummer 000165 DFL 65,00



# RFC 1631, May 1994

For instance, in the example of figure 2, both stubs A and B internally use class A address 10.0.0.0. Stub A's NAT is assigned the class C address 198.76.29.0, and Stub B's NAT is assigned the class C address 198.76.28.0. The class C addresses are globally unique no other NAT boxes can use them.

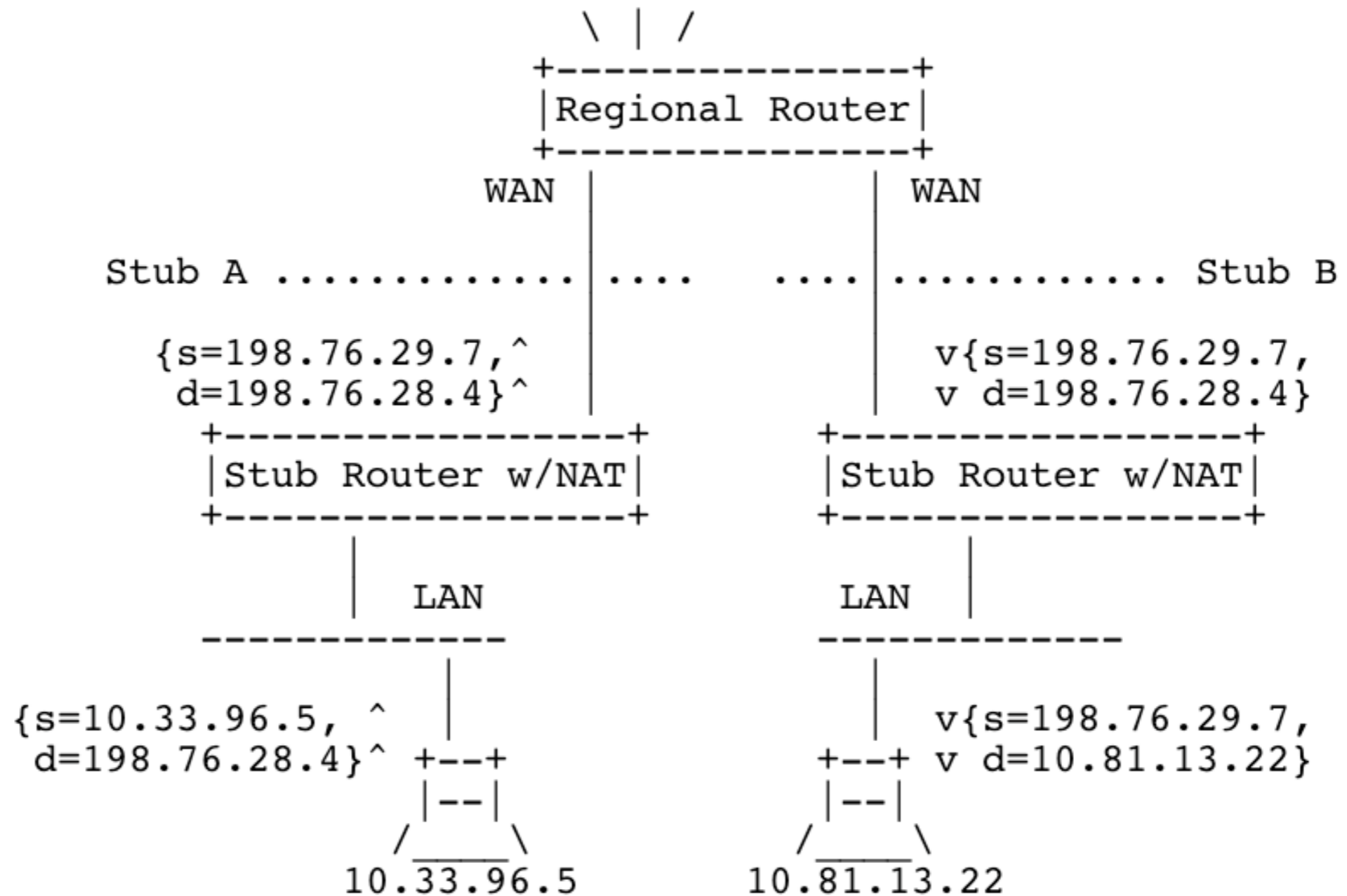
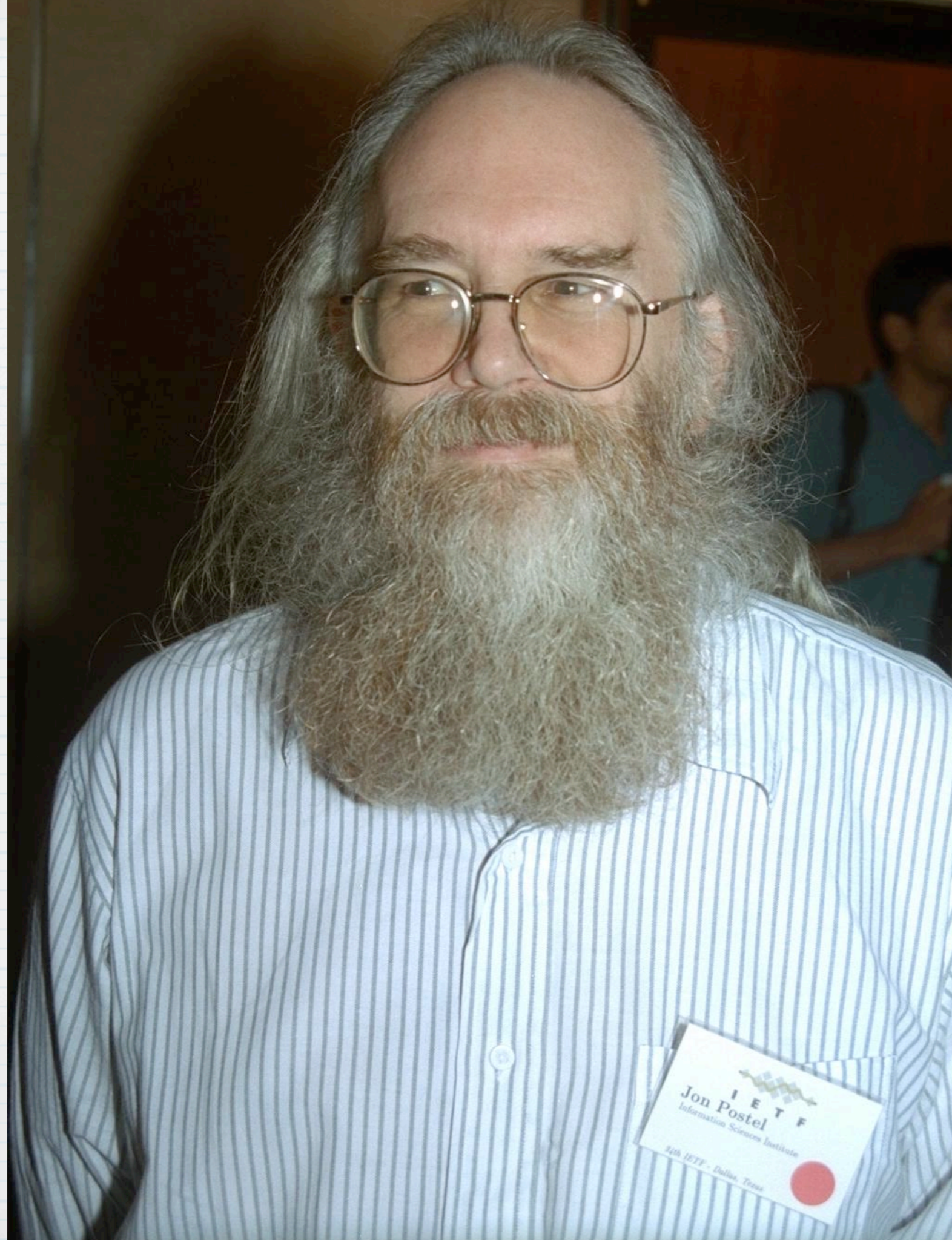

Figure 2: Basic NAT Operation





**IETF 34 Dallas,  
December 1995**

**Photo: Peter Löthberg**



# IETF 48 Pittsburgh, July 2000

<—Hoping for an IETF  
meeting here someday





**IETF 49 San Diego,  
December 2000**





**IETF 49 San Diego,  
December 2000**





**IETF 50 Minneapolis,  
March 2001**





IETF 51 London,  
August 2001



I E T F

BT exact  
TECHNOLOGIES

IETF Meeting, London 2001

Welcome



To Registration and Terminal Room

This is a NO SMOKING event



# IETF 52 Salt Lake City, December 2001







IETF 54 Yokohama, July 2002





横浜  
国際会議場  
Yokohama International Hall  
SINCE  
1998

Yokohama  
19

IETF 54 Yokohama,  
July 2002





**IETF 55 Atlanta,  
November 2002**



# IETF 56 San Francisco, March 2003



Photo: Olaf Kolkman





**IETF 59 Seoul, February 2004**



**IETF 59 Seoul, February 2004**







**IETF 59 Seoul, February 2004**



IETF 60 San Diego,  
August 2004







**IETF 64, Vancouver, November 2005**



**IETF 65 Dallas**

**March 19-24, 2006**

**Host: Nokia**









